

Technisches Datenblatt

Separator Modell MCF 150

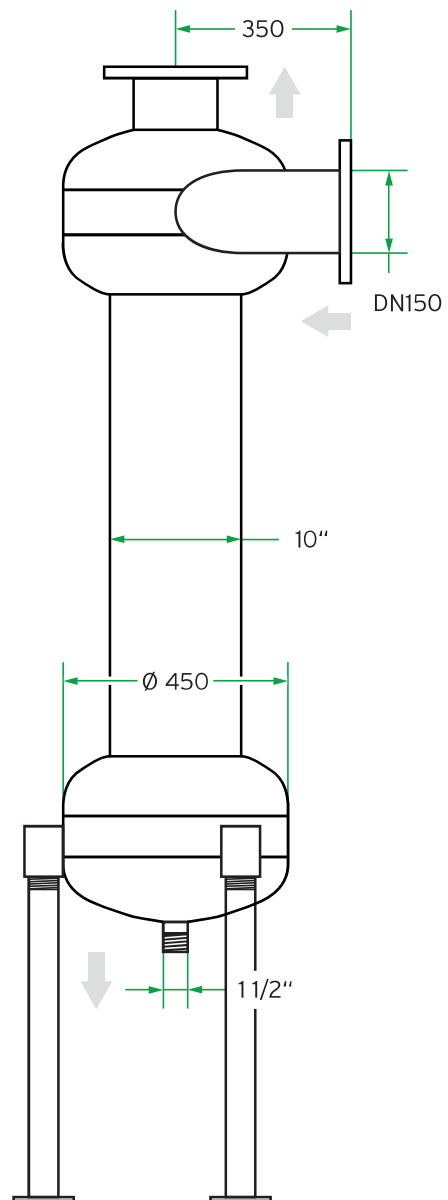
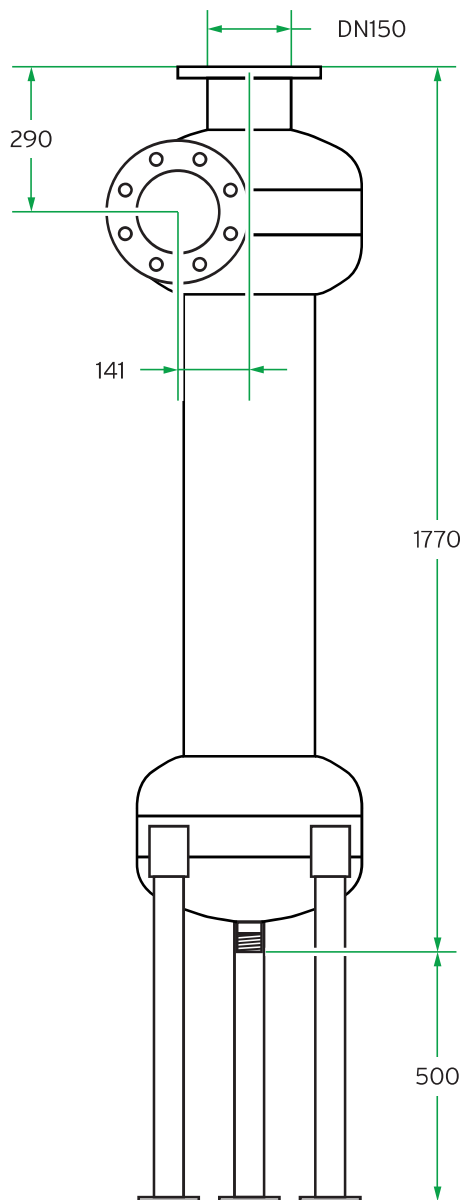

Technische Daten

Anschlüsse:	DN150 (6")
Durchfluss:	110 - 270 m ³ /h
Druckabfall:	0,3 - 0,8 bar
Material:	SS304 Edelstahl